

DTC Series 35

Duct Temperature Controller

DTC series 35 duct mounted temperature controllers are designed to provide P+I control of 1, 2 or 3 analogue (0-10V) outputs.

The single stage offers heating or cooling control with an option for summer/winter changeover, whilst the 2 stage controller provides for heating and cooling in sequence with the 3 stage controller providing the capability to control heat/ventilation and cooling in sequence. The controllers are designed for direct duct mounting and are available with or without Low Limit control function.

Product Codes

Product Code	Description
DTC135	1 x 0-10V output
DTC235	2 x 0-10V outputs
DTC335	3 x 0-10V outputs
DTC135/L	1 x 0-10V output with Low Limit
DTC235/L	2 x 0-10V outputs with Low Limit
DTC335/L	3 x 0-10V outputs with Low Limit

Features

- 24V AC/DC Supply
- 1,2 or 3 controlled outputs
- Proportional plus Integral control action
- Optional remote setpoint adjustment
- Summer/Winter changeover (single output controller)
- With or without Low Limit sensor control
- Option for Summer Compensation
- Option for OFF or ECO (set back) mode
- Option for BMS setpoint reset
- Output for BMS monitoring
- Direct Duct Mounting

Specification

Power Supply:	24V AC/DC (+/- 15%)
Power Consumption:	12mA plus 0-10V outputs
Outputs:	0-10V (5mA max) controlled 0-10V actual temperature (monitoring)
Inputs:	0-10V external sensor for Summer Compensation 0-10V signal for BMS SP reset RSA Remote Setpoint 2 Wire (500-10500ohms)
Sensing Element:	10k3A1 thermistor (control & low limit)
Settings:	Setpoint (SP) range 5-35°C Proportional Band (Pb) 1-12°C Dead Band (Db) 0-3°C (2 & 3 Stage only) ECO (set back/set up) 0-10°C Integral action (I time) 10, 50, 100 or 200 secs Low Limit (L/L) 10-30°C
Option Selections (DIL):	I Time (Switch 1&2) Off or ECO (switch 3) Summer Compensation (switch 4) BMS SP reset (switch 5)
Terminals:	Max. cable size 1.0mm
Operating Temperature:	0-50°C
Dimensions:	Housing: 110mm high, 110mm wide, 65mm deep Probe: 300mm long, 10mm dia.
Mounting:	Duct mounting flange
Product Code:	See Table

Dimensions

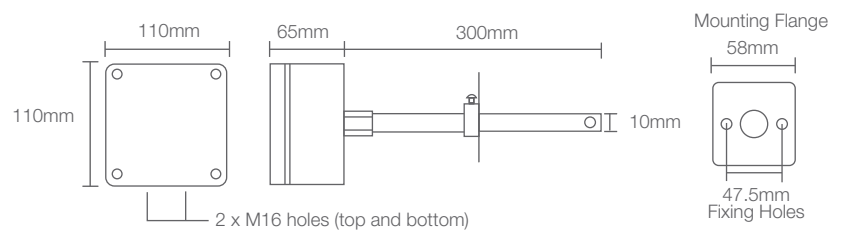

TECHNICAL INFORMATION

DTC135 Single Output P+I Temperature Controller & DTC135/L with Low Limit

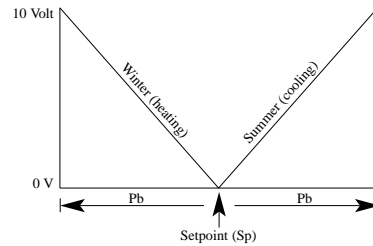
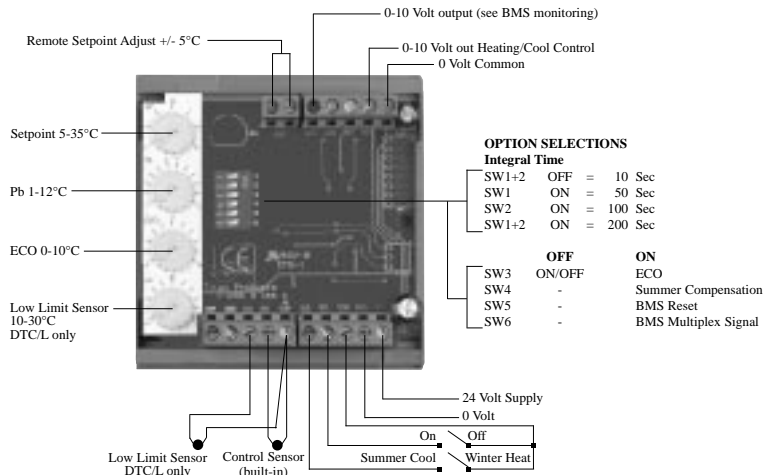

DTC235 Two Stage P+I Temperature Controller & DTC235/L with Low Limit

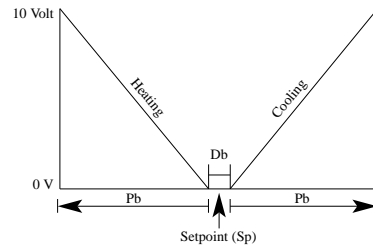
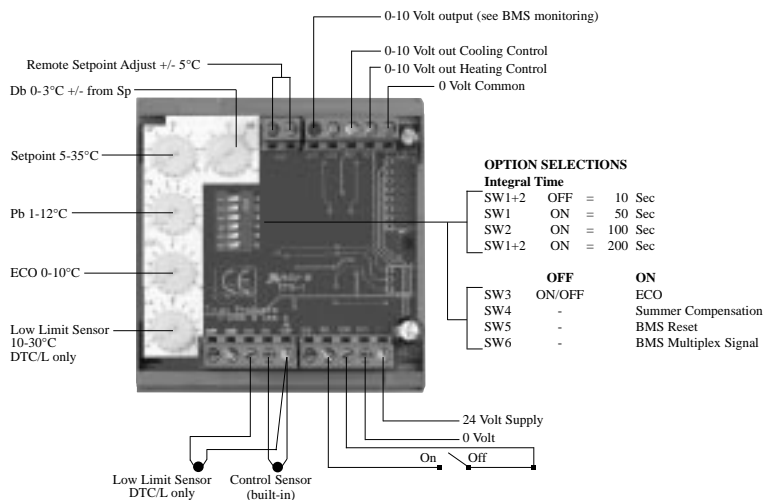

DTC335 Three Stage P+I Temperature Controller & DTC335/L with Low Limit

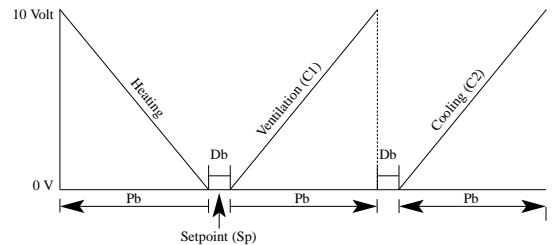
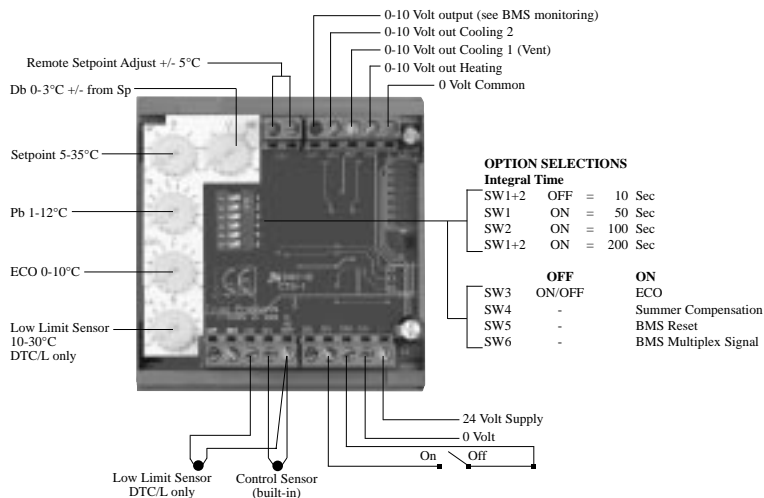

RSA5 Remote Setpoint Adjuster +/- 5°C

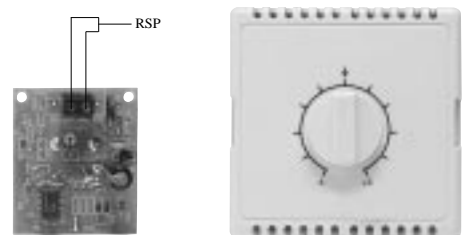

PRODUCT TYPES

- DTC135 1 x 0-10V output
- DTC235 2 x 0-10V outputs
- DTC335 3 x 0-10V outputs
- DTC135/L 1 x 0-10V output with Low Limit
- DTC235 2 x 0-10V outputs with Low Limit
- DTC335 3 x 0-10V outputs with Low Limit
- RSA5 Remote Setpoint Adjuster +/-5°C
- TPT/RSA5 Room Temperature Sensor with Setpoint Adjuster
- TPDS/S Duct Mounted Temperature Sensor 150mm long
- TPVOS/40 External Temperature Sensor for Summer Compensation

OPTIONS AND CONTROL FUNCTIONS

(See back for full connection details. All diagrams show the DTC controller positioned in extract duct)

ON/OFF

The controller can be switched ON/Off from a remote time clock or switch by connecting across terminals DI1 and Com. In the OFF mode the controlled outputs drive to zero volts (closed). These connections are also used for putting the controller into ECO mode when option switch 3 is selected ON.

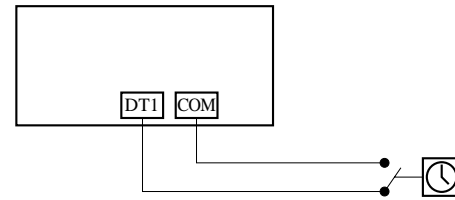

TEMPERATURE SENSORS

The controller temperature sensors are 10K3 thermistors
 S1 is the control sensor room and can be room (TPTRS) or duct mounted (TPTDS)
 S2 is the Low Limit temperature and is duct mounted type TPTDS
 S0 External temperature sensor (TPVOS/40) output 0-10V range -10 +40°C

SUMMER/WINTER CONTROL

With the single output controller Summer/Winter changeover is achieved by connecting a volt free switch between D2 and Com (normally open for heating). For auto seasonal changeover a thermostat (T1) can be used set at the required temperature.

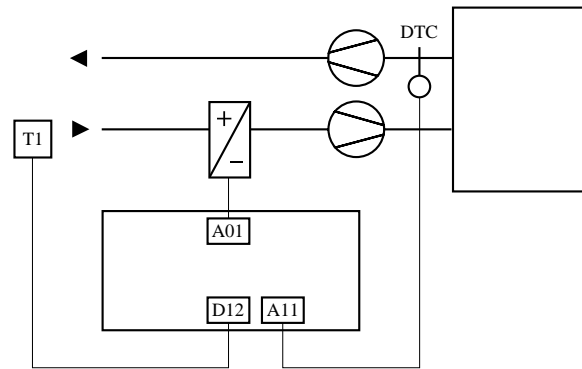
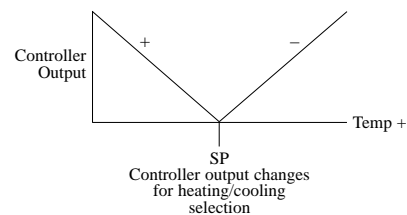

REMOTE SETPOINT

A remote setpoint RSA5 connected across terminals RSP provides an adjustment to the actual controller setpoint of +/- 5°C. The controller automatically detects if the Reset Setpoint is connected.

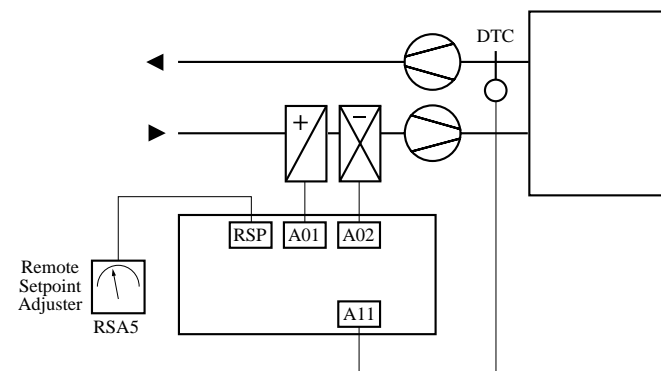
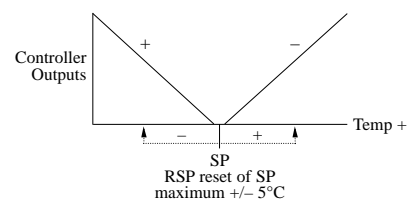

ECO SETTING

When ECO is selected by DIL switch 3 and the controller is switched Off. The heating setpoint is reduced and the cooling setpoint is increased by the amount selected (range 0-10°C). The ECO function creates a wide dead band both sides of the controller setpoint (SP).

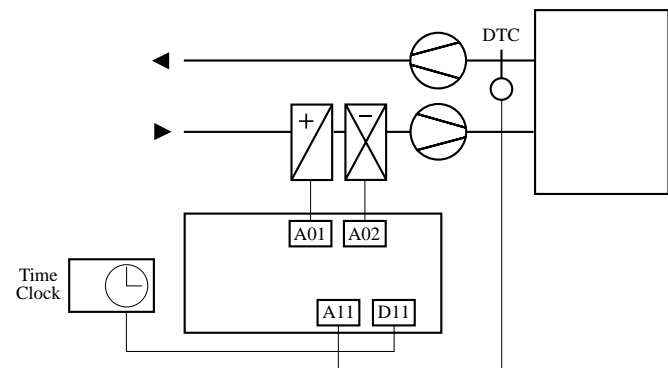
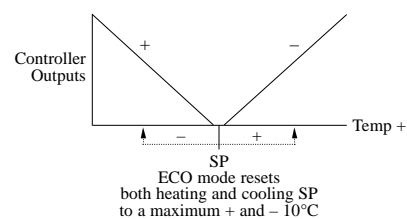

SUMMER COMPENSATION

For summer compensation select DIL switch 4 and connect an outside 0-10V temperature transmitter (SO) with a range of -10 to + 40°C into AI4. Summer compensation starts when the outside temperature reaches 2°C above the controller setpoint. The effect of Summer compensation is to increase the Setpoint (SP) by 0.5°C for every 1°C rise in outside temperature above the activation level. The maximum SP reset is +3°C which is reached when the outside temperature rises to 8°C above the SP. The purpose of this summer compensation is to reduce the effects of thermal shock when people enter the building and for energy savings.

Example: -
 With a SP of 21°C and an outside temperature of 23°C no SP reset takes place. If the outside temperature increases to 25°C then the SP is automatically increased to 22°C

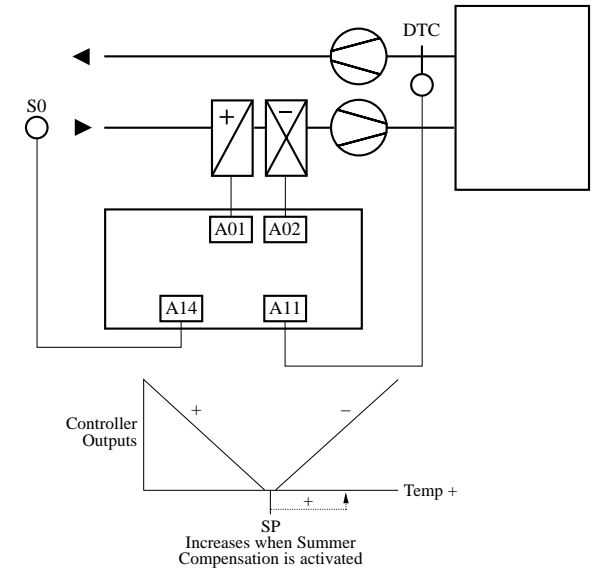

BMS MONITORING AND RESET

The controller actual temperature can be measured 0-10V on output AO4 (ranged 0 to 100°C). This signal can be used to monitor the temperature remotely by a digital display or BMS input. When a BMS input is used AO4 can be a multiplexed output by selecting DIL SW6 to on. The single multiplexed signal provides the value of SP, calculated SP. Actual temperature, low limit temperature (if used). *See chart below. A BMS reset can be achieved by selecting DIL switch 5 and connecting a 0-10V input signal into AI3. This reset range is +/- 5°C from an input of 0-10V i.e. 5V input = no influence on the setpoint.

MULTIPLEX A04 SIGNAL			
Condition	Output V	Range C	Time
Start	10V	N/A	4 Sec
SP (Actual)	1-7	5-35	4 Sec
SP (Calculated)	1-7	5-35	4 Sec
Actual Temp	0-9.5	0-45	4 Sec
Low Limit Temp	0-9.5	0-45	4 Sec

BACK TO START

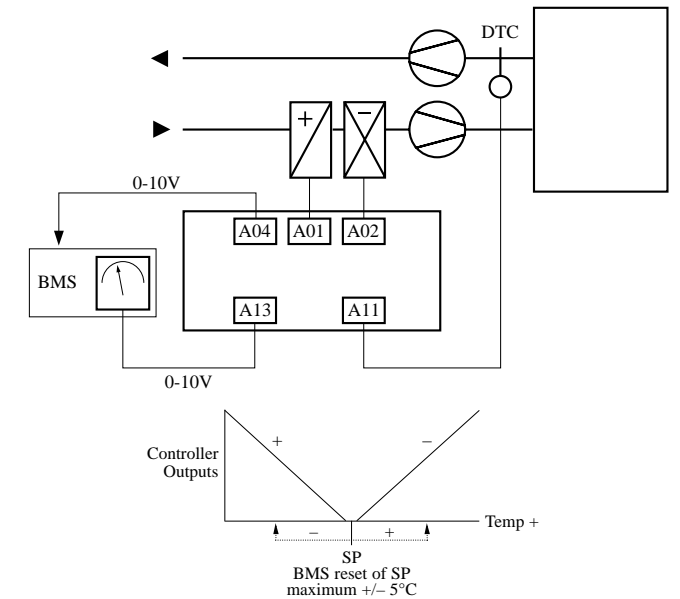

LOW LIMIT (FOR 1,2 OR 3 STAGE CONTROLLER)

On controllers offering Low Limit control option the temperature sensor (S2) situated in the discharge air connects between AI2 and Com. The controller automatically detects if the low limit sensor is connected. The Low Limit setting (range 10-30°C) is to prevent cold air being discharged into the occupied space. The low limit is activated at the Low Limit setting + the controller proportional band (Pb) and the action is to increase the SP on a 1 to 1 ratio.

Example: -
 With a L/L of 15°C and a Pb of 2°C then the activation of L/L reset takes place when the discharge air drops below 17°C and for every 1°C below this level the SP is increased +1°C.

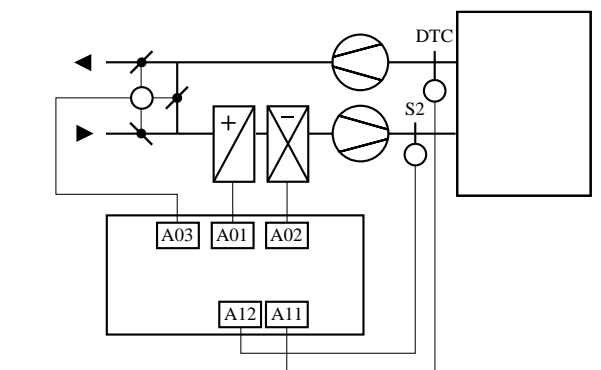

DTC335 & DTC335/L MINIMUM FRESH AIR & ECONOMY COOLING

During normal ON operation the 3 stage controllers feature a standard 20% minimum fresh air position on the ventilation control output. Therefore AO3 operates between 2-10V in the ON condition but closes down to 0V in the OFF condition.

For Economy Cooling the AO3 ventilation output automatically closes down to the minimum fresh air value (2V) any time the controller starts to output the cooling signal. The deadband between the ventilation and cooling stages prevents short cycling of this action under normal operation.

