



STC Room Temperature Controller

The STC range of temperature controllers provide P+I control and are designed to auto self tune the control parameters to the area of application. The controllers are available with external or internal setpoint adjustment.

This auto tune facility sets the controller P-band and integral action automatically to the system response and continuously monitors the control parameters to ensure the best control action is always achieved.

Specification

Power Supply:	24V AC/DC (+/- 15%)
Power Consumption:	12mA plus 0-10V outputs
Outputs:	0-10V (5mA max)
Inputs:	10k3A1 Thermistor (s) DI1 (VF) for ON/OFF, ECO, NSB DI2 (VF) for summer/winter control
Settings:	Setpoint (SP) range 10-30°C ECO (NSB)/Frost 0-15°C Low Limit Sensor 10-20°C
Option Selections:	SW 1&2 off = On/Off Sw 1 on 2 off = Frost Protection SW 2 on 1 off = ECO (NSB) SW3 not used SW4 not used
Terminals:	Max. cable size 1.0mm
Operating Temperature:	0-50°C
Dimensions:	80mm high, 80mm wide, 29mm deep
Product Code:	See Table

Product Codes

Product Code	Description
STC/C/130	1 x 0-10V output for heating or cooling. Includes concealed setpoint adjustment, inbuilt temperature sensor, inputs for heating/cooling selection and ECO, Frost Protection or ON/Off.
STC/C/130/L	1 x 0-10V output for heating or cooling with Low Limit sensor setting. Includes concealed setpoint adjustment, inbuilt temperature sensor, inputs for heating/cooling selection and ECO, Frost Protection or ON/Off.
STC/E/130	130 1 x 0-10V output for heating or cooling. Includes external setpoint adjustment, inbuilt temperature sensor, inputs for heating/cooling selection and ECO, Frost Protection or ON/Off.vv
STC/E/130/L	L 1 x 0-10V output for heating or cooling with Low Limit sensor setting. Includes external setpoint adjustment, inbuilt temperature sensor, inputs for heating/cooling selection and ECO, Frost Protection or ON/Off.
STC/C/230	2 x 0-10V output for heating and cooling. Includes concealed setpoint, inbuilt temperature sensor, inputs for heating/cooling selection and ECO, Frost Protection or ON/Off.
STC/C/230/L	2 x 0-10V output for heating and cooling with Low Limit sensor setting. Includes concealed setpoint, inbuilt temperature sensor, inputs for heating/cooling selection and ECO, Frost Protection or ON/Off.
STC/E/230	2 x 0-10V output for heating and cooling. Includes external setpoint, inbuilt temperature sensor, inputs for heating/cooling selection and ECO, Frost Protection or ON/Off.
STC/E/230/L	2 x 0-10V output for heating and cooling with Low Limit sensor setting. Includes external setpoint, inbuilt temperature sensor, inputs for heating/cooling selection and ECO, Frost Protection or ON/Off.

*Note: - If a remote control temperature sensor is used then the inbuilt sensor must be disconnected by cutting the leads to the sensor.

Features

- 24V AC/DC Supply
- Auto Tuning Proportional plus Integral control action
- 1 or 2 x 0-10V outputs
- Summer/Winter selection (STC130 & STC130/L)
- ON/OFF, ECO or Frost Protection input
- Internal or remote temperature sensor
- Optional low limit sensor and setting
- External or Concealed temperature setpoint
- Wall mounting

Dimensions

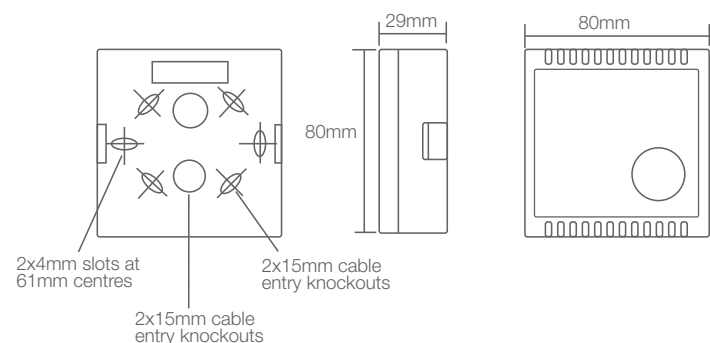

TECHNICAL INFORMATION

STC ROOM TEMPERATURE CONTROLLER

The STC range of temperature controllers provide P+I control and are designed to auto self tune the control parameters to the area of application. This auto tune facility sets the controller P-band and integral action automatically to the system response and continuously monitors the control parameters to ensure the best control action is always achieved.

If the STC incorporates an inbuilt temperature sensor then the controller should be positioned in a location that is representative of the required temperature and should not be installed directly above or close to radiators or directly influenced by ventilation discharge outlets, sun light or other uncontrolled heat gains.

STC130 & STC130/L (Single output with or without Low Limit)

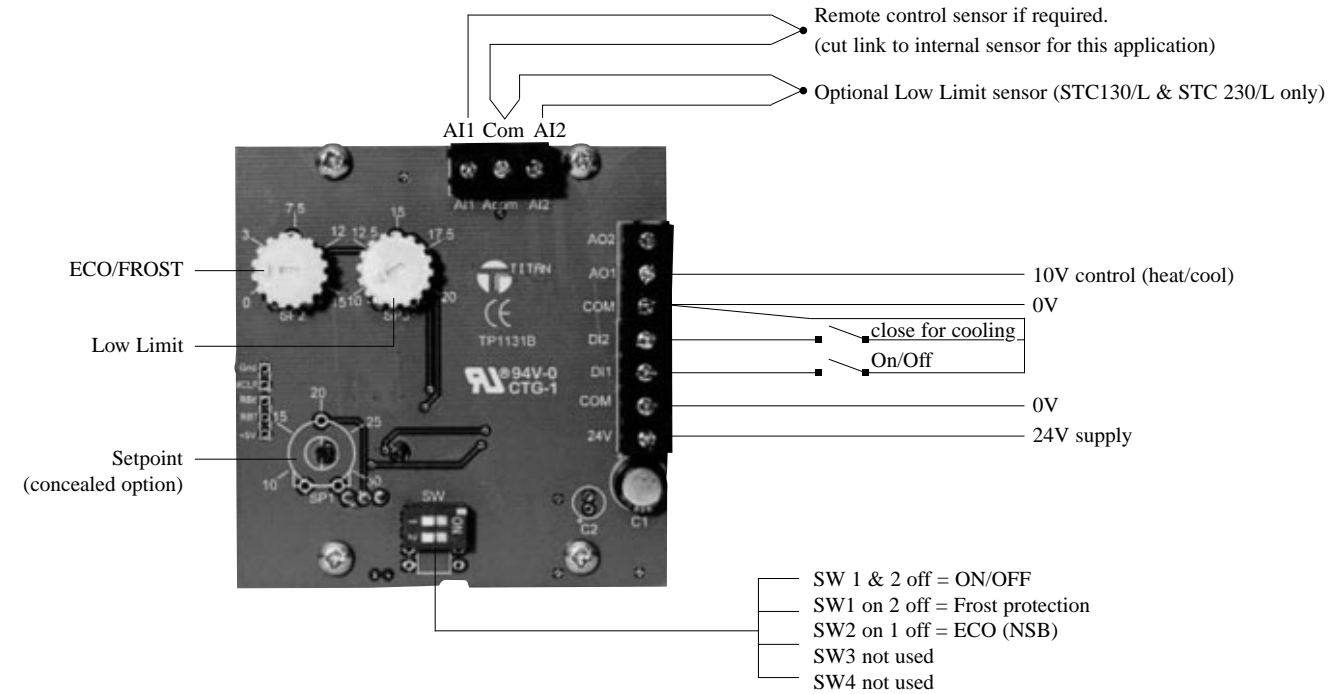

STC230 & STC230/L (Two outputs with or without Low Limit)

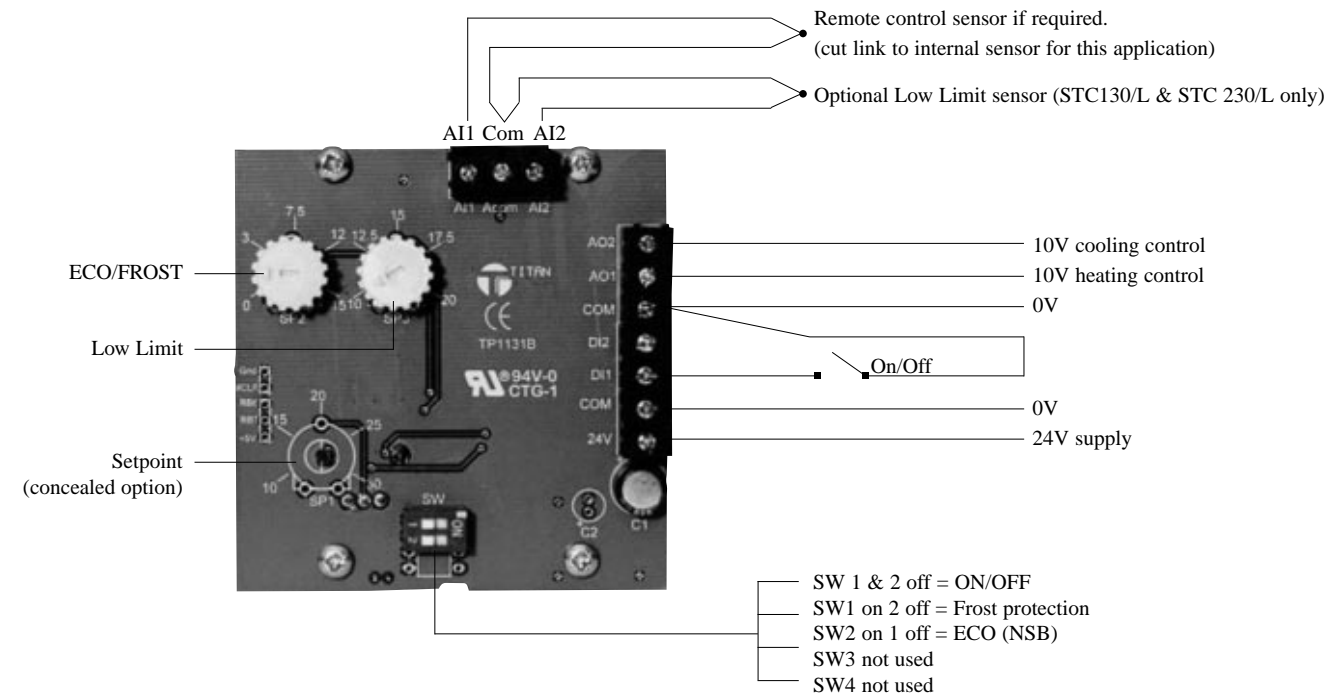

STC Temperature Controller Issue 02 Provisional information

ON/OFF

The controller can be switched ON/Off from a remote time clock or switch by connecting across terminals DI1 and Com 0V (Closed circuit ON, Open circuit OFF). In the OFF mode with DIL switch 1 & 2 Off the controlled outputs drive to zero Volts (closed). These connections are also used for putting the controller into ECO mode or Frost protection dependant on the options selected.

(See separate sections for Frost Protection and ECO).

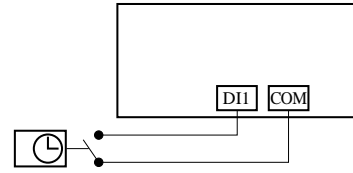

FROST PROTECTION

Frost protection is selected by DIL switch 1 ON and DIL switch 2 Off. In Frost Protection mode when the controller is switched Off (open circuit DI1 and COM). The controller operates at the actual value set on the SP2 (range 0-15°C). If the measured control temperature on AI1 falls to the setting on SP2 then the output AO1 (heating) goes to 10V. When the measured temperature rises 2°C above the SP2 setting then AO1 reverts to 0V. This control action is On/Off (10V/0V) with a 2°C switching differential (SD).

Important: - The STC controllers do not have a separate output to initiate start up of the central plant. The STC will only operate at the reduced temperature setting for the zone it is controlling. It is therefore required to make a separate provision to start any central plant such as boilers, pumps and fans.

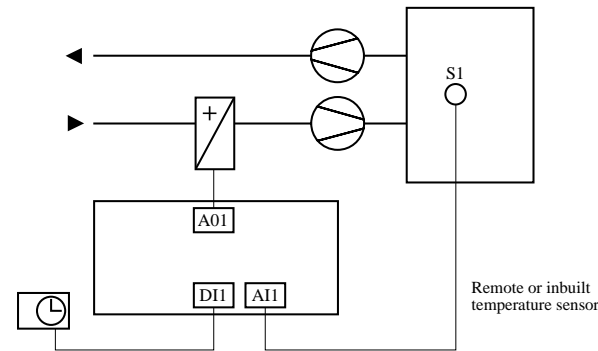
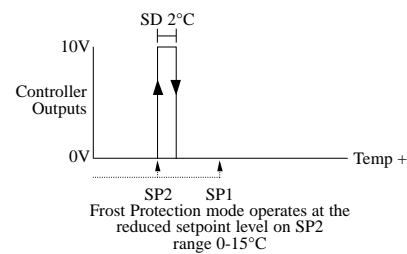

ECO SETTING

ECO is selected by DIL switch 1 Off and switch 2 On. In the ECO mode when the controller is switched Off (open circuit DI1 and Com) the controller introduces a new control point either side of the actual controller setpoint (SP1) by the actual value set on SP2 (range 0-15°C).

For example with an SP1 of 20°C and an ECO setting (SP2) of 5°C heating control point is 15°C and cooling control point is 25°C. Should the measured temperature reach either of the ECO values then the controller will take up full modulating control.

Important: - The STC controller does not have a separate output to initiate start up of the central plant. The STC will only operate at the setpoint temperature setting and ECO value for the zone it is controlling. It is therefore required to make a separate provision to start any central plant such as boilers, pumps and fans.

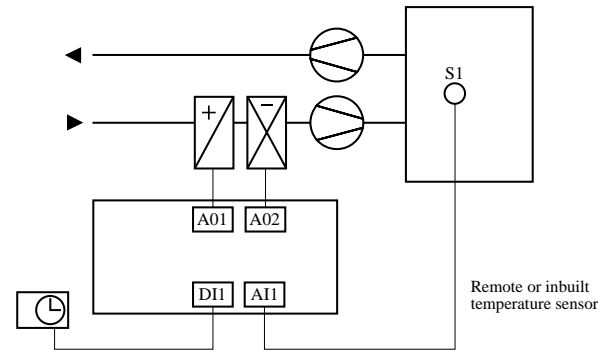
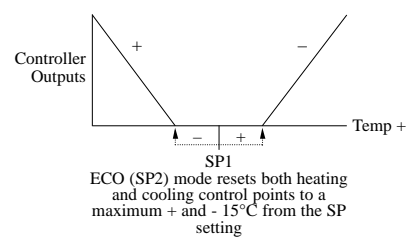

SUMMER/WINTER CONTROL

With the single output controller STC130 and STC130/L Summer/Winter changeover is achieved by connecting a Volt free switch between DI2 and Com (normally open for heating or closed for cooling). For auto seasonal changeover a thermostat (T1) can be used set at the required temperature.

Important: - If auto seasonal changeover is used then the signal for this operation must be linked in some way with the central plant to ensure correct operation.

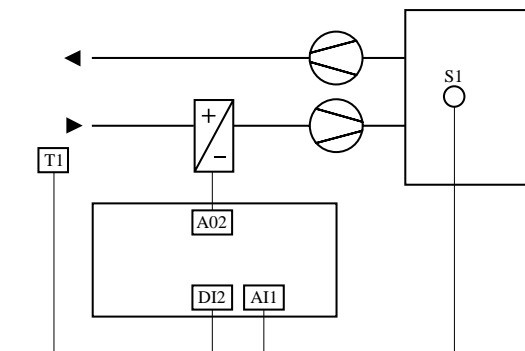
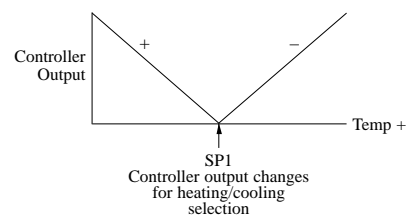

TWO STAGE CONTROL HEATING/COOLING

The STC230 and STC230/L provide two stage heating & cooling control with 2 x 0-10V DC controlled outputs. The controller has a preset +/- 0.5°C dead band either side of the setpoint (SP1) to the start of the heating and cooling cycles. The control action is auto tuning and only the control setpoint needs selecting.

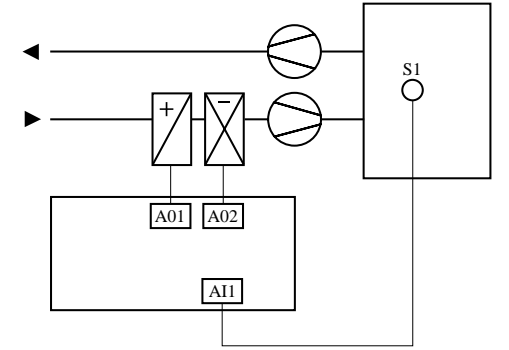
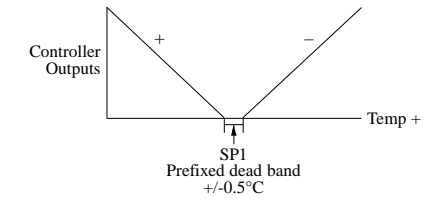

LOW LIMIT (STC130/L & STC230/L ONLY)

On controllers offering Low Limit control option the temperature sensor (S2) situated in the discharge air connects between the terminals AI2 and Com. The controller automatically detects if the low limit sensor is connected. The Low Limit setting SP3 (range 10-20°C) is to prevent cold air being discharged into the occupied space. The low limit reset control is activated 3°C above the Low Limit setpoint value and the action is to proportionally increase the actual control setpoint SP1 on a 1 to 1 ratio.

For example: -

With a Low Limit setting of 15°C on SP3 then the activation of Low Limit reset takes place when the discharge air drops below 18°C and at a discharge air temperature of 15°C the maximum reset influence is exerted.

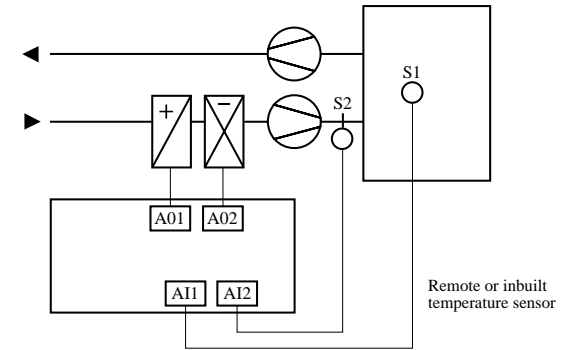
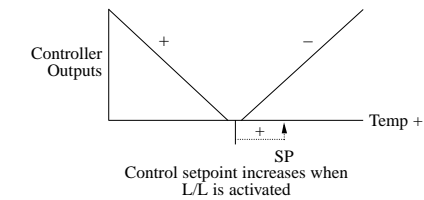

CONTROLLER TYPES

STC/C/130	1 x 0-10V output for heating or cooling. Includes concealed setpoint adjustment, inbuilt temperature sensor, inputs for heating/cooling selection and ECO, Frost Protection or ON/Off.
STC/C/130/L	1 x 0-10V output for heating or cooling with Low Limit sensor setting. Includes concealed setpoint adjustment, inbuilt temperature sensor, inputs for heating/cooling selection and ECO, Frost Protection or ON/Off.
STC/E/130	1 x 0-10V output for heating or cooling. Includes external setpoint adjustment, inbuilt temperature sensor, inputs for heating/cooling selection and ECO, Frost Protection or ON/Off.
STC/E/130/L	1 x 0-10V output for heating or cooling with Low Limit sensor setting. Includes external setpoint adjustment, inbuilt temperature sensor, inputs for heating/cooling selection and ECO, Frost Protection or ON/Off.
STC/C/230	2 x 0-10V output for heating and cooling. Includes concealed setpoint, inbuilt temperature sensor, inputs for heating/cooling selection and ECO, Frost Protection or ON/Off.
STC/C/230/L	2 x 0-10V output for heating and cooling with Low Limit sensor setting. Includes concealed setpoint, inbuilt temperature sensor, inputs for heating/cooling selection and ECO, Frost Protection or ON/Off.
STC/E/230	2 x 0-10V output for heating and cooling. Includes external setpoint, inbuilt temperature sensor, inputs for heating/cooling selection and ECO, Frost Protection or ON/Off.
STC/E/230/L	2 x 0-10V output for heating and cooling with Low Limit sensor setting. Includes external setpoint, inbuilt temperature sensor, inputs for heating/cooling selection and ECO, Frost Protection or ON/Off.

Note: - If a remote control temperature sensor is used then the inbuilt sensor must be disconnected by cutting the leads to the sensor.

Other related products

This list of products covers compatible temperature sensors and control modules that may be useful in the control application. If you need any help in selecting products best suited for your application then contact the sales office.

TPTRS	Room wall mounted temperature sensor. Can be used for the remote control sensor.
TPTDS	Duct mounted temperature sensor. Can be used for the remote control sensor and the Low Limit temperature sensor.
IO/ARM	Single voltage dependant relay module can be used to switch electrical loads for heating or cooling. (see data sheet M-019).
IO/2RM	2 switching relay module can be used for applications to sequence 2 electrical loads for heating/cooling (see data sheet M-004).
IO/DOM2	2 switching relay module can be used for applications to sequence 2 electrical loads for heating/cooling (see data sheet M-013).
IO/DOM4	4 switching relay module can be used for applications to sequence 4 electrical loads for heating/cooling (see data sheet M-011).
IO/DOM6	6 switching relay module can be used for applications to sequence 6 electrical loads for heating/cooling (see data sheet M-009).