

IO/AD3W/20-100, IO/AD3W/5-75 & IO/AD3W/30-100 Window Controller

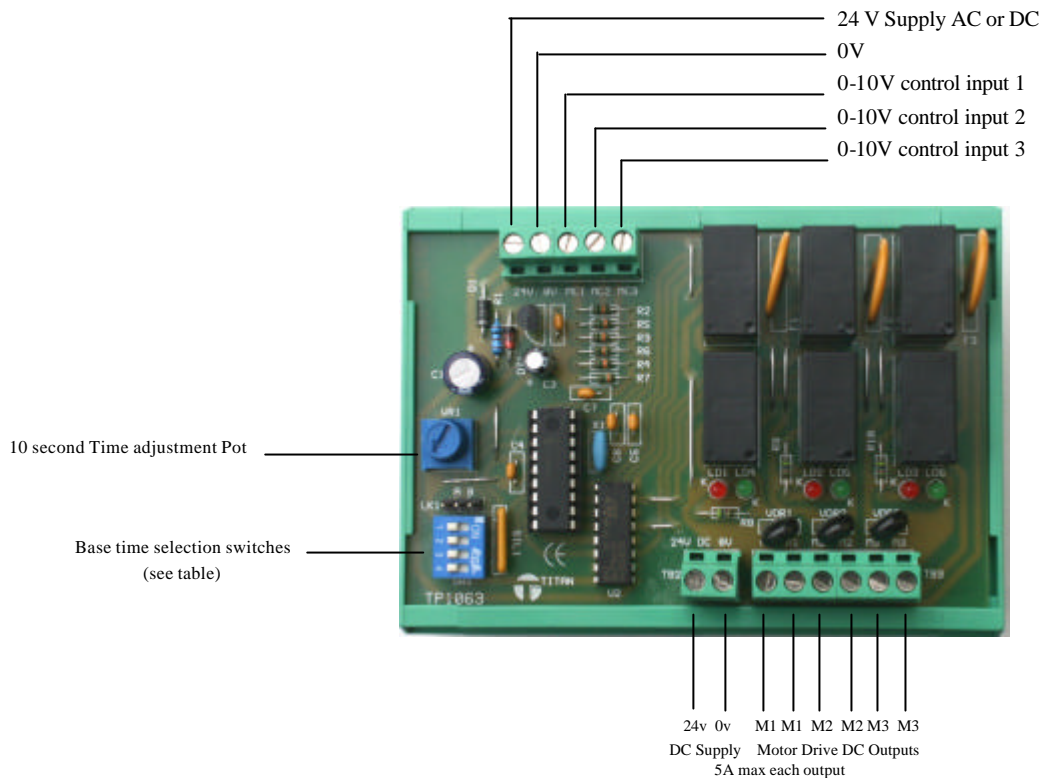

Important: Max combined current through this module must NOT exceed 9amps

DESCRIPTION

The motor drive relay board is mounted in a DIN rail carrier and is designed to provide an interface between the control signals from the BMS to the motors driving the natural ventilation actuators on louvers, windows and blinds to the desired position. It provides three separate bi-directional output drives which can be independently controlled from three 0-10V input signals. The unit is microprocessor controlled and is fitted with 6 x 5A relays arranged in pairs to provide the three output drives. Each drive is independently fused at 5A with a self-resetting fuse and all the drive outputs are supplied from two terminals to which an independent 24V DC supply should be connected. Each output is fitted with a varistor to limit switching transients and has red and green LED's to indicate relay status (off, opening or closing).

The supply to the unit logic is independent of the above and is 24V AC/DC, the three 0-10V inputs are referenced to this supply.

SPECIFICATION

- > 24V AC/DC supply
- > Power consumption module only 60mA
- > 3 x 0-10V input control signals (20K impedance)
- > 24V DC supply for motor control
- > 3 x Forward/Reverse motor control outputs (*each 5 amp max – Combined max must not exceed a total of 9 amps.*)
- > DIN Rail mounted
- > Size 113mm wide 82mm high 45mm deep
- > Order Code: IO/AD3W/20-100
IO/AD3W/5-75
IO/AD3W/30-100



Measurement Devices for Control Systems

TITAN Products Ltd.
Unit 7 Southside, Bredbury Park Industrial Estate
Stockport SK6 2SP. England.
Tel: - +44 (0)161 406 6480, Fax: - +44 (0)161 494 8309
Email:- admin@titanproducts.com
Website: - www.titanproducts.com

© Copyright Titan Products Ltd. 2006

Output Control

The output control is time proportional to the motor maximum drive time and the level of the 0 to 10V input signal for a given channel, for example a 50% position requires an input signal of 5V to be maintained. The maximum drive time must be set at commissioning after timing the actual drive time of the actuator. The actuator time setting is done by a three way binary coded DIP switch allowing the base time to be selected and a finger turn potentiometer to give an additional 10 secs of adjustment. The actuator run time settings are shown in the following table:-

IO/AD3W/20-100

SW1	SW2	SW3	Base time	Pot Adjustment
Off	Off	Off	20 secs	20 to 30 secs
On	Off	Off	30 secs	30 to 40 secs
Off	On	Off	40 secs	40 to 50 secs
On	On	Off	50 secs	50 to 60 secs
Off	Off	On	60 secs	60 to 70 secs
On	Off	On	70 secs	70 to 80 secs
Off	On	On	80 secs	80 to 90 secs
On	On	On	90 secs	90 to 100 secs

IO/AD3W/5-75

SW1	SW2	SW3	Base time	Pot Adjustment
Off	Off	Off	5 secs	5 to 15 secs
On	Off	Off	15 secs	15 to 25 secs
Off	On	Off	25 secs	25 to 35 secs
On	On	Off	35 secs	35 to 45 secs
Off	Off	On	45 secs	45 to 55 secs
On	Off	On	55 secs	55 to 65 secs
Off	On	On	65 secs	65 to 75 secs
On	On	On	75 secs	75 to 85 secs

IO/AD3W/30-100

SW1	SW2	SW3	Base time	Pot Adjustment
Off	Off	Off	30 secs	30 to 40 secs
On	Off	Off	40 secs	40 to 50 secs
Off	On	Off	50 secs	50 to 60 secs
On	On	Off	60 secs	60 to 70 secs
Off	Off	On	70 secs	70 to 80 secs
On	Off	On	80 secs	80 to 90 secs
Off	On	On	90 secs	90 to 100 secs
On	On	On	100 secs	100 to 110 secs

SW4 is not used in this application.

On power up the module drives all outputs to the fully closed position for the time period set on the switches and the pot plus 20%, this is to synchronize the module and ensure that the actuators are at the fully closed position. After this initial power up condition the synchronisation will be carried out automatically each time the actuators are driven to the fully closed position, this is done by driving the close signal for an additional 20% of the drive time, while this is being carried out the analogue input signal is ignored.

If desired the 0 to 10V inputs can be looped on the terminals to provide simultaneous drive to all three outputs. The input impedance of the 0-10V signals is 20K which gives 0.5 mA current drain per input with a 10V signal.

IMPORTANT

When using Time bases less than 10 seconds it is recommended that the control signal is set to give "Fixed Position" control from "Fixed Voltage" values. Modulating control signals at this low time based can cause poor positional control which can result in loss of synchronisation.

