

INPUT/OUTPUT MODULE:- IO/PCM PHASE CUT OUTPUT

2-Control Inputs - PCM2
 1-Control Input - PCM1

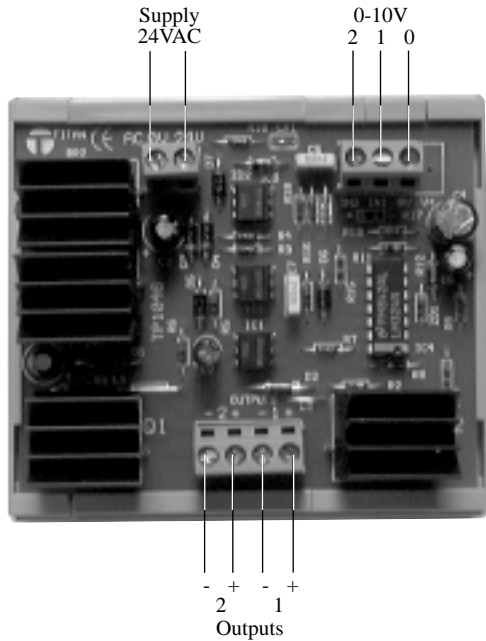

2-Control Outputs - PCM2- 40VA
 1-Control Output - PCM1-80VA

90mm

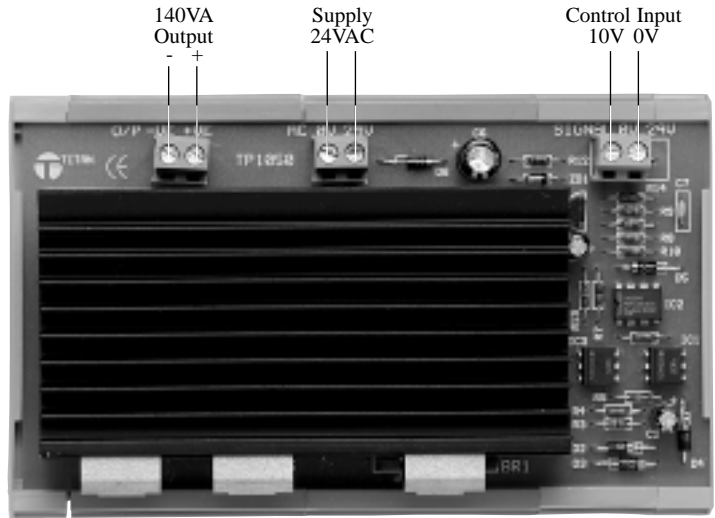

PCM1/140

136mm

DESCRIPTION

The IO/PCM module is designed to convert a 0-10 Volt control signal to a 20 Volt phase cut output.

FEATURES

- * 24 Volt AC supply
- * Converts 0-10 Volt to 20 Volt phase cut output
- * 2 phase cut outputs available 40VA each
- * High power single output rated at 80VA or 140VA
- * DIN Rail mounting

SPECIFICATION

Input	0-10 Volt DC signal
Output	20 Volt phase cut output
Power Supply	24 Volt AC ($\pm 15\%$)
Operating Temp	-10 to + 40°C
Terminals	Max cable size 2mm
Operating Temperature	-10 to + 40°C
Dimensions	IO/PCM2/40 & IO/PCM1/80 80mm High 80mm 90mm Wide 136mm 60mm Deep 60mm IO/PCM1/140 136mm Wide
Mounting	DIN Rail
Order Code	IO/PCM2/40 (2X40 VA outputs) IO/PCM1/80 (1X80 VA output) IO/PCM1/140 (1X140 VA)



Measurement Devices for Control Systems

TECHNICAL INFORMATION

INPUT/OUTPUT MODULE:- IO/PCM PHASE CUT OUTPUT

The IO/PCM module is designed to provide a 0 to 20V phase cut signal from a 0-10V signal input obtained from a controller or BMS outstation. The following guidelines must be followed to ensure correct operation.

CONNECTIONS

Common Supply

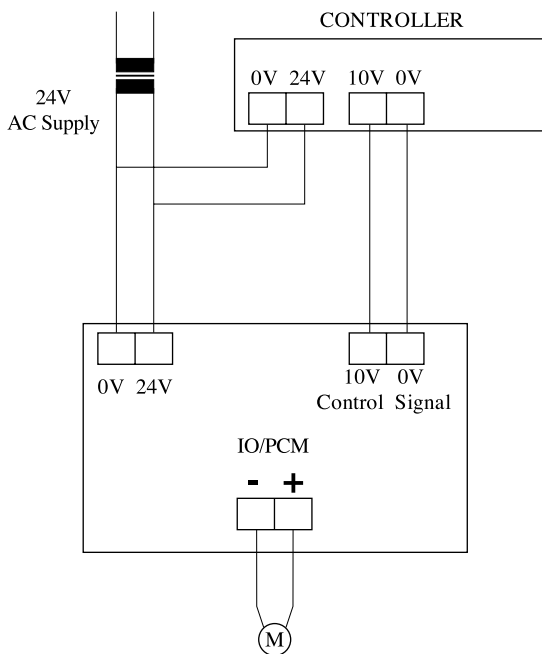

Separate Supplies (0V must be connected together)

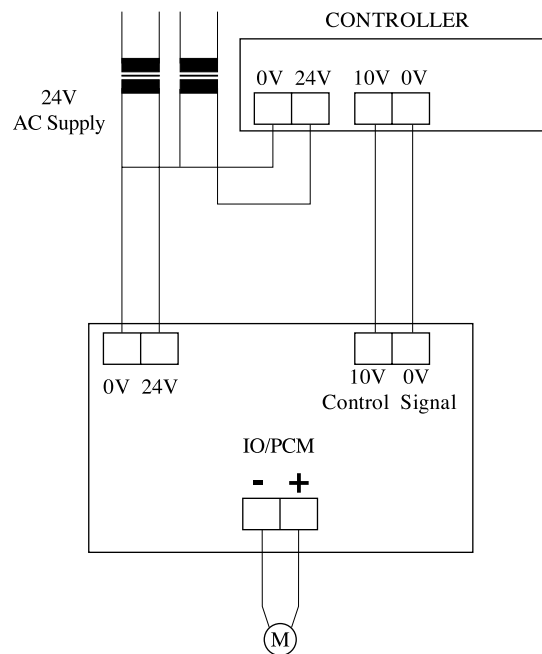

Testing the IO/PCM

The IO/PCM must be connected using one of the above methods for correct operation. Failure to do so will result in false reading or no controlled output.

- 1 - The 0-10V control input signal must be 2 wire to prevent problems with volt drop during operation.
- 2 - The 0V of the 24V supply must be common to the IO/PCM and the Controller.
- 3 - The electrical load (M) must be connected when measuring the IO/PCM controlled output.

The following reading should be obtained from the PCM output with respect to the control input signal.

Open Circuit 0V input	=	Fail safe ON 20V DC output. (no load connected 36V)
0 Volt control input	=	0V output (no load connected 0V)
10 Volt control input	=	20V output (no load connected 36V)

TITAN Products Ltd.

Unit 7 Southside, Bredbury Park Industrial Estate, Bredbury, Stockport SK6 2SP England.
Tel :- 0161 406 6480 Fax :- 0161 494 8309 E-mail: admin@titanproducts.com Website: www.titanproducts.com

© Copyright Titan Products Ltd. 2003